

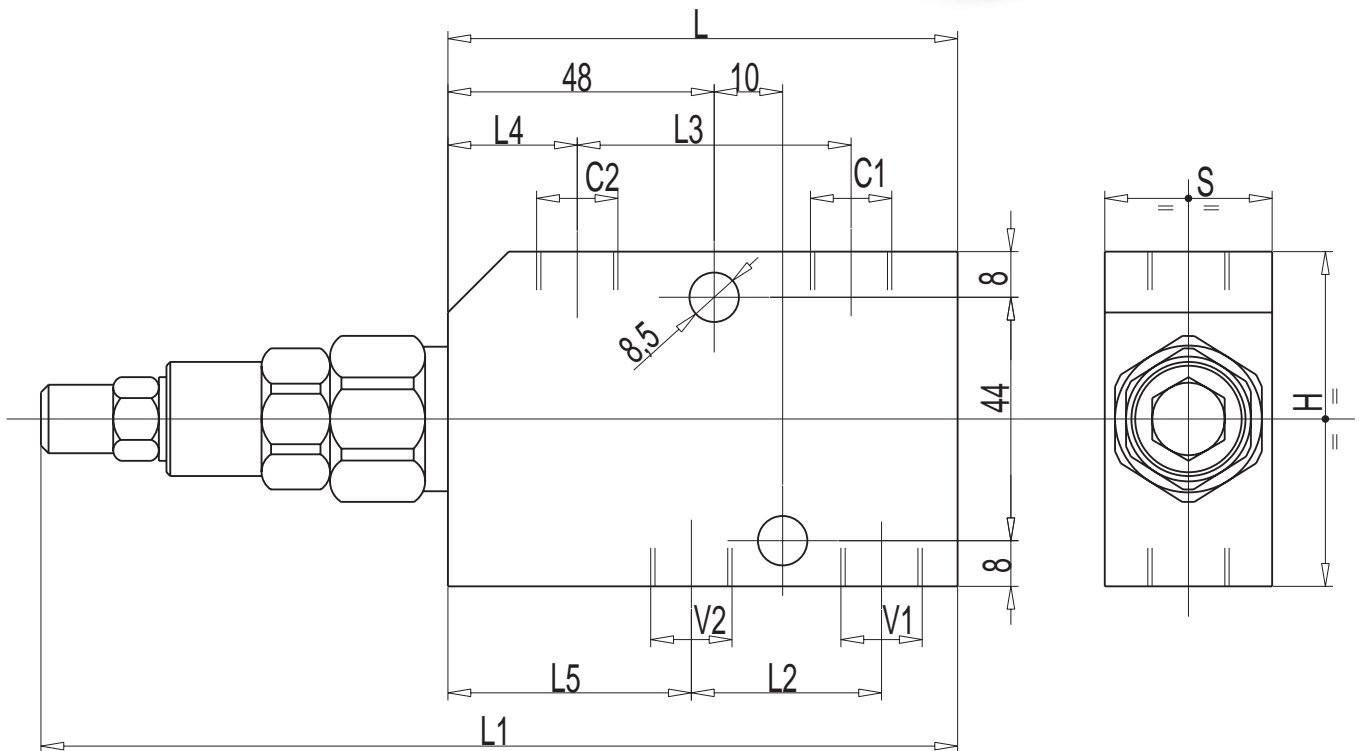

## Enkelwerkende balanceerklep Valves d'équilibrage simple effet

Materiaal / Matière: Staal / Acier

Max.druk / Pression max.: 250 BAR

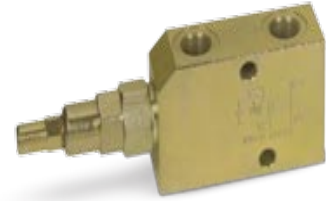

Hydraulisch Schema /  
Schéma hydraulique

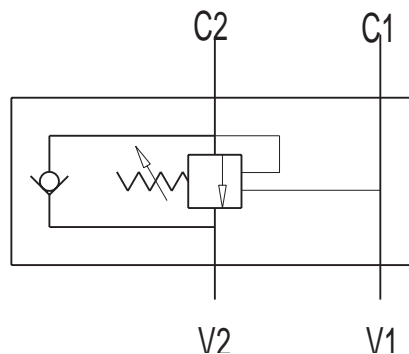

Bestelnr. Référence	TYPE	Stuurdrukverhouding Rapport de pilotage	Max.Debiet / Débit MAX FLOW	V1-V2 C1-C2	L	L1	L2	L3	L4	L5	H	S
			Lt./min.	BSP	mm							
	VBCD 3/8 S.E.	1 : 3,1	35	G3/8	90	162	32	48	23	42	60	30
	VBCD 1/2 S.E.	1 : 3,1	50	G1/2	90	162	35	48	23	40,5	60	30