

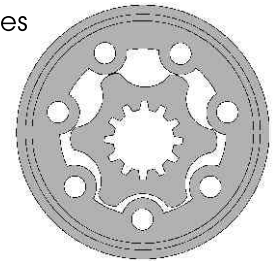

The MAP Series are a competitive type, small package and provides big power which is designed with shaft distributive flow. These compact units are very versatile and can be used in various applications where space is limited yet still generating power enough to get the job done.



**Specifications**

TYPE		MAP MAPW 50	MAP MAPW 80	MAP MAPW 100	MAP MAPW 125	MAP MAPW 160	MAP(1) MAPW 200	MAP(2) MAPW 200	MAP(1) MAPW 250	MAP(2) MAPW 250	MAP(1) MAPW 315	MAP(2) MAPW 315	MAP(1) MAPW 400	MAP(2) MAPW 400
Displacement (c.c/rev)		50.8	78.8	98.6	123.5	158.6	197.9	197.9	247.5	247.5	316.5	316.5	396.5	396.5
Max. speed (rpm)	Cont	1180	760	600	485	380	302	302	240	240	190	190	150	150
	Int(3)	1380	940	750	600	475	380	380	302	302	235	235	190	190
Max. Torque (da Nm)	Cont	9.3	14.9	19	23.4	31	36.4	35.9	45.2	35.1	46.3	34.2	48.2	34.8
	Int(3)	12	19	23	29	37	45.2	43.5	58.9	46.8	54.3	49.2	55.5	45.4
	Peak(4)	14	21.9	26.5	36.2	42.6	54.5	54.5	64.2	58.5	70.5	68.4	78.7	68.8
Max. output (Kw)	Cont	10.2	10.1	10.3	10	10	10	9.6	9.4	7.4	7.5	5.6	6.3	4.6
	Int(3)	12.3	12.3	12.5	12	12	12	12	12	12	9	9	7.8	7.8
Max. pressure drop (bar)	Cont	140	140	140	140	140	140	135	135	105	115	80	90	65
	Int(3)	175	175	175	175	175	175	160	175	140	135	115	110	90
	Peak(4)	210	210	210	210	210	210	210	200	175	175	160	160	140
Max. oil flow (l/min)	Cont	50	60	60	60	60	60	60	60	60	60	60	60	60
	Int(3)	60	75	75	75	75	75	75	75	75	75	75	75	75
Max. Inlet pressure (bar)	Cont	160	160	160	160	160	160	160	160	160	160	160	160	160
	Int(3)	175	175	175	175	175	175	175	175	175	175	175	175	175
	Peak(4)	210	210	210	210	210	210	210	210	210	210	210	210	210
Weight (kg)		5.6	5.7	5.9	6.0	6.2	6.4	6.4	6.6	6.6	6.9	6.9	7.4	7.4

- (1) MAP...motor with CA, CB, TA, SH, SB shafts.      (2) MAP...motor with C, CO, T, S shafts.  
 (3) Intermittent operation rating applies to 6 sec. of every minute      (4) Peak load rating applies to 0.6 sec of every minute

TYPE		MAP MAPW 50	MAP MAPW 80	MAP MAPW 100	MAP MAPW 125	MAP MAPW 160	MAP(1) MAPW 200	MAP(2) MAPW 200	MAP(1) MAPW 250	MAP(2) MAPW 250	MAP(1) MAPW 315	MAP(2) MAPW 315	MAP(1) MAPW 400	MAP(2) MAPW 400
Displacement (in.3/r )		3.1	4.8	6	7.5	9.7	12.1	12.1	15.1	15.1	19.3	19.3	24.2	24.2
Max. speed (rpm)	Cont	1180	760	600	485	380	302	302	240	240	190	190	150	150
	Int(3)	1380	940	750	600	475	380	380	302	302	235	235	190	190
Max. Torque (lb-in)	Cont	820	1320	1682	2068	2744	3221	3177	3996	3108	4097	3028	4268	3083
	Int(3)	1062	1682	2036	2567	3275	3996	3850	4950	4144	4810	4353	4910	4017
	Peak(4)	1239	1938	2345	3204	3770	4823	4823	5680	5181	6235	6057	6965	6093
Max. output (hp)	Cont	13.7	13.5	13.8	13.4	13.4	13.4	12.9	12.6	9.9	10.1	7.5	8.4	6.2
	Int(3)	16.5	16.5	16.8	16.1	16.1	16.1	16.1	16.1	16.1	12.1	12.1	10.5	10.5
Max. pressure drop (psi)	Cont	2030	2030	2030	2030	2030	2030	1960	1960	1525	1615	1160	1305	945
	Int(3)	2540	2540	2540	2540	2540	2540	2320	2540	2030	1960	1665	1600	1305
	Peak(4)	3045	3045	3045	3045	3045	3045	3045	2900	2540	2540	2320	2320	2030
Max. oil flow (gpm)	Cont	13	16	16	16	16	16	16	16	16	16	16	16	16
	Int(3)	16	20	20	20	20	20	20	20	20	20	20	20	20
Max. Inlet pressure (psi)	Cont	2320	2320	2320	2320	2320	2320	2320	2320	2320	2320	2320	2320	2320
	Int(3)	2540	2540	2540	2540	2540	2540	2540	2540	2540	2540	2540	2540	2540
	Peak(4)	3045	3045	3045	3045	3045	3045	3045	3045	3045	3045	3045	3045	3045
Weight (lbs)		12.3	12.5	13	13.2	13.6	14.1	14.1	14.5	14.5	15.2	15.2	16.3	16.3



The MAPH Series are a competitive type, small package and provides big power which is designed with shaft distributive flow. These compact units are very versatile and can be used in various applications where space is limited yet still generating power enough to get the job done.

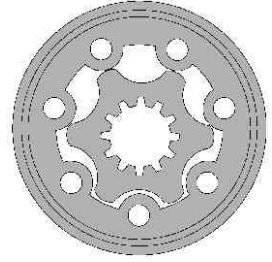

**Specifications**

TYPE		MAPH 50	MAPH 80	MAPH 100	MAPH 125	MAPH 160	MAPH 200	MAPH 250	MAPH 315	MAPH 400
Displacement (c.c/rev)		50.8	78.8	98.6	123.5	158.6	197.9	247.5	316.5	396.5
Max. speed (rpm)	Cont	1180	760	600	485	380	302	240	190	150
	Int(3)	1380	940	750	600	475	380	302	235	190
Max. Torque (da Nm)	Cont	9.3	14.9	19	23.4	31	35.9	35.1	34.2	34.8
	Int(3)	12	19	23	29	37	43.5	46.8	49.2	45.4
	Peak(4)	14	21.9	26.5	36.2	42.6	54.5	58.5	68.4	68.8
Max. output (Kw)	Cont	10.2	10.1	10.3	10	10	9.6	7.4	5.6	4.6
	Int(3)	12.3	12.3	12.5	12	12	12	12	9	7.8
Max. pressure drop (bar)	Cont	140	140	140	140	140	135	105	80	65
	Int(3)	175	175	175	175	175	160	140	115	90
	Peak(4)	210	210	210	210	210	210	175	160	140
Max. oil flow (l/min)	Cont	60	60	60	60	60	60	60	60	60
	Int(3)	75	75	75	75	75	75	75	75	75
Max. Inlet pressure (bar)	Cont	160	160	160	160	160	160	160	160	160
	Int(3)	175	175	175	175	175	175	175	175	175
	Peak(4)	210	210	210	210	210	210	210	210	210
Weight (kg)		5.6	5.7	5.9	6.0	6.2	6.4	6.6	6.9	7.4

(3) Intermittent operation rating applies to 6 sec. of every minute

(4) Peak load rating applies to 0.6 sec of every minute

TYPE		MAPH 50	MAPH 80	MAPH 100	MAPH 125	MAPH 160	MAPH 200	MAPH 250	MAPH 315	MAPH 400
Displacement (in.3/r )		3.1	4.8	6	7.5	9.7	12.1	15.1	19.3	24.2
Max. speed (rpm)	Cont	1180	760	600	485	380	302	240	190	150
	Int(3)	1380	940	750	600	475	380	302	235	190
Max. Torque (lb-in)	Cont	820	1320	1682	2068	2744	3177	3108	3028	3083
	Int(3)	1062	1682	2036	2567	3275	3850	4144	4353	4017
	Peak(4)	1239	1938	2345	3204	3770	4823	5181	6057	6093
Max. output (hp)	Cont	13.7	13.5	13.8	13.4	13.4	12.9	9.9	7.5	6.2
	Int(3)	16.5	16.5	16.8	16.1	16.1	16.1	16.1	12.1	10.5
Max. pressure drop (psi)	Cont	2030	2030	2030	2030	2030	1960	1525	1160	945
	Int(3)	2540	2540	2540	2540	2540	2320	2030	1665	1305
	Peak(4)	3045	3045	3045	3045	3045	3045	2540	2320	2030
Max. oil flow (gpm)	Cont	16	16	16	16	16	16	16	16	16
	Int(3)	20	20	20	20	20	20	20	20	20
Max. Inlet pressure (psi)	Cont	2320	2320	2320	2320	2320	2320	2320	2320	2320
	Int(3)	2540	2540	2540	2540	2540	2540	2540	2540	2540
	Peak(4)	3045	3045	3045	3045	3045	3045	3045	3045	3045
Weight (lbs)		12.3	12.5	13.0	13.2	13.6	14.1	14.5	15.2	16.3

A : Continuous operation

B : Intermittent operation rating applies to 6 sec. of every minute.

MAP/MAPH50

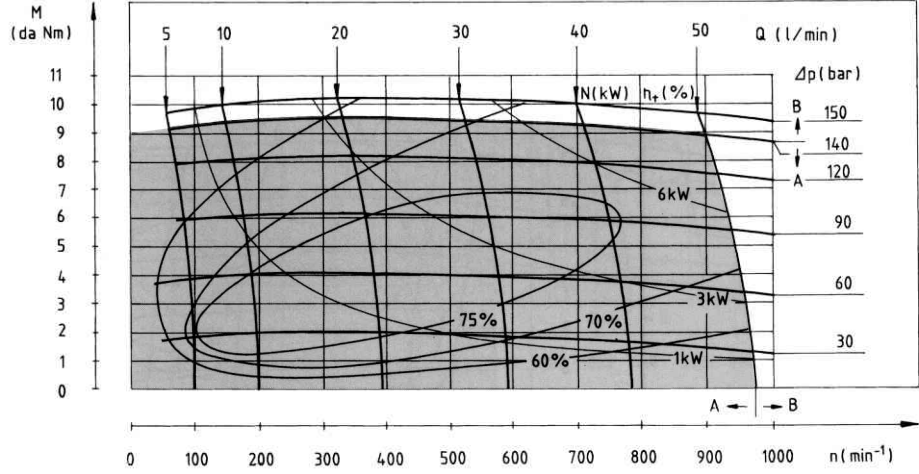

MAP/MAPH80

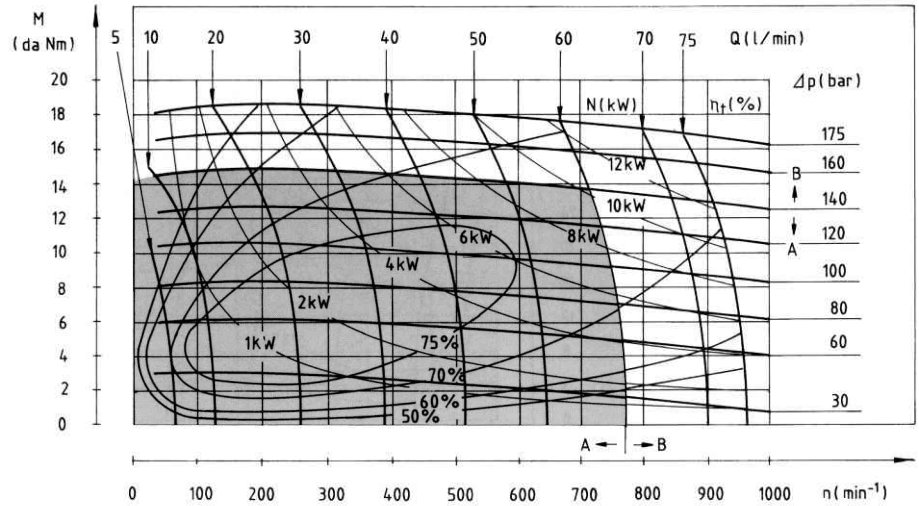

MAP/MAPH100

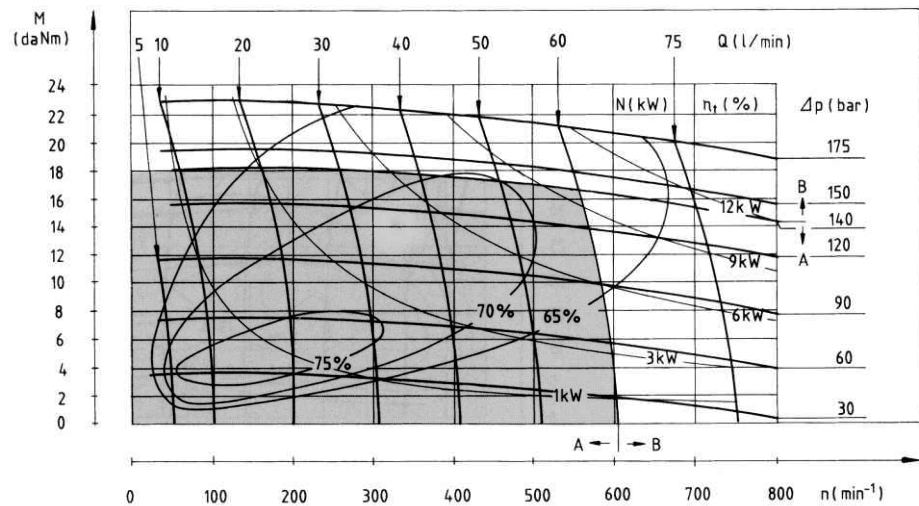

A : Continuous operation

B : Intermittent operation rating applies to 6 sec. of every minute.

MAP/MAPH125

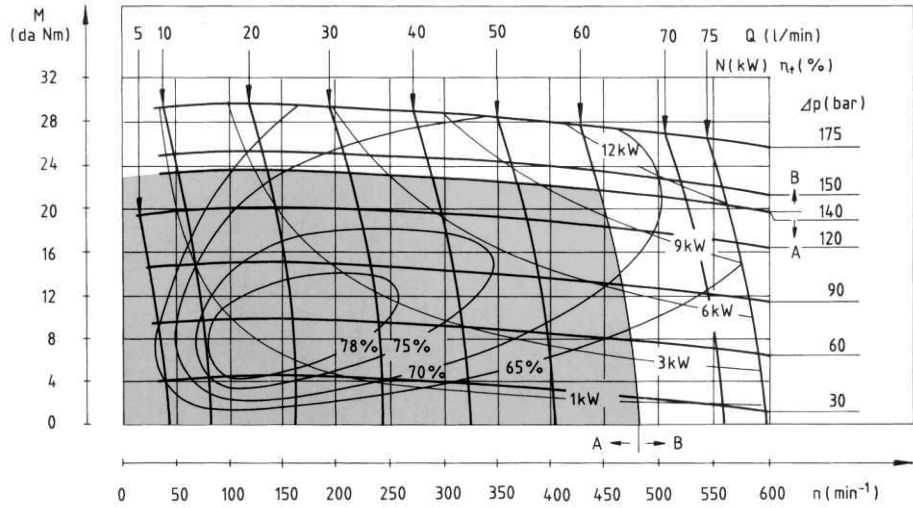

MAP/MAPH160

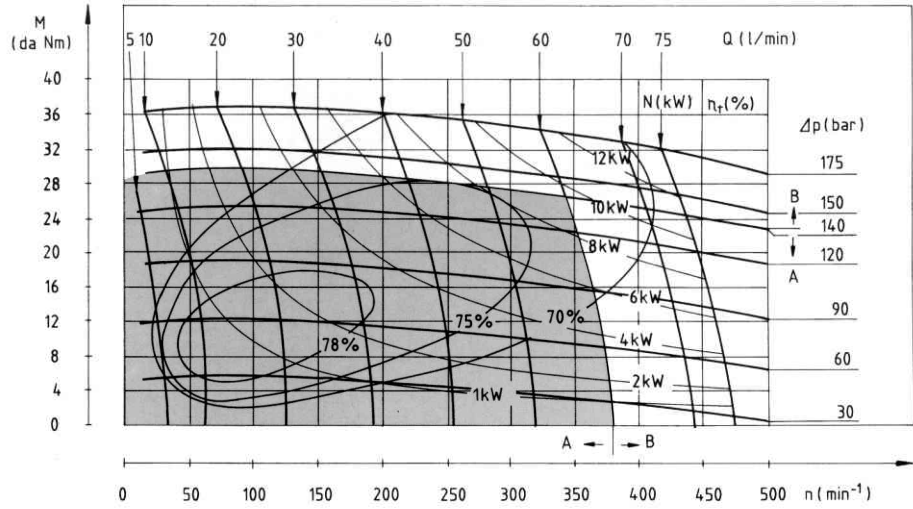

MAP/MAPH200

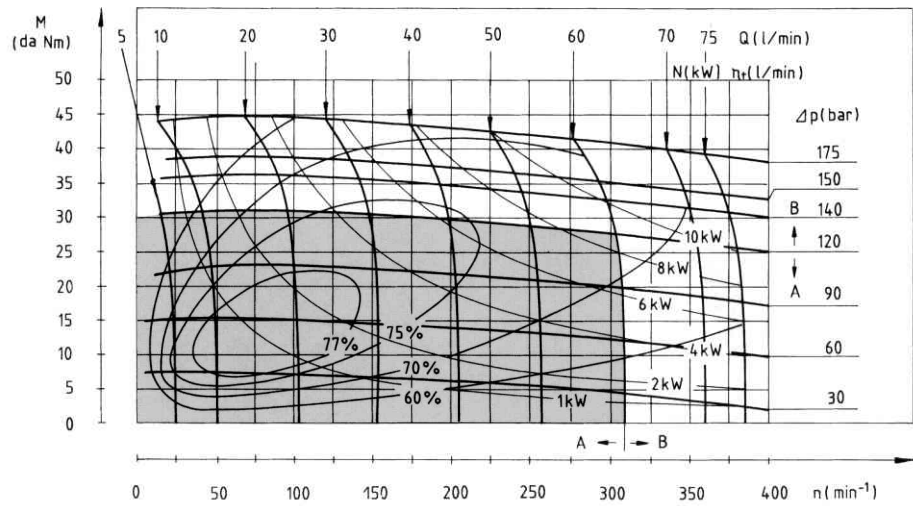

A : Continuous operation

B : Intermittent operation rating applies to 6 sec. of every minute.

MAP/MAPH250

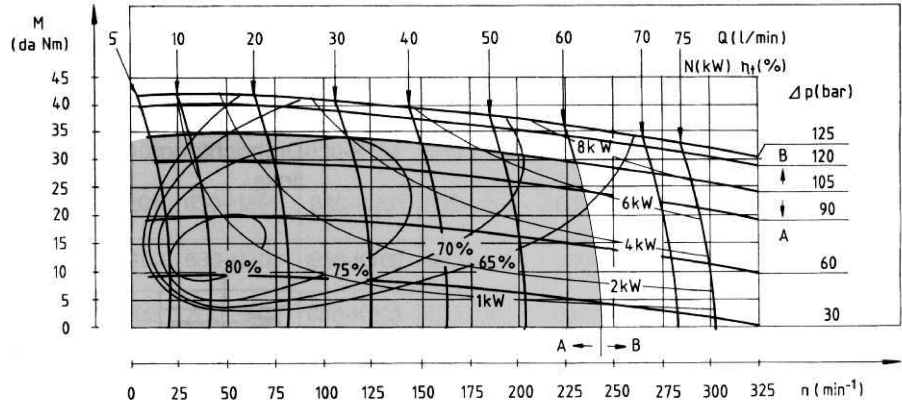

MAP/MAPH315

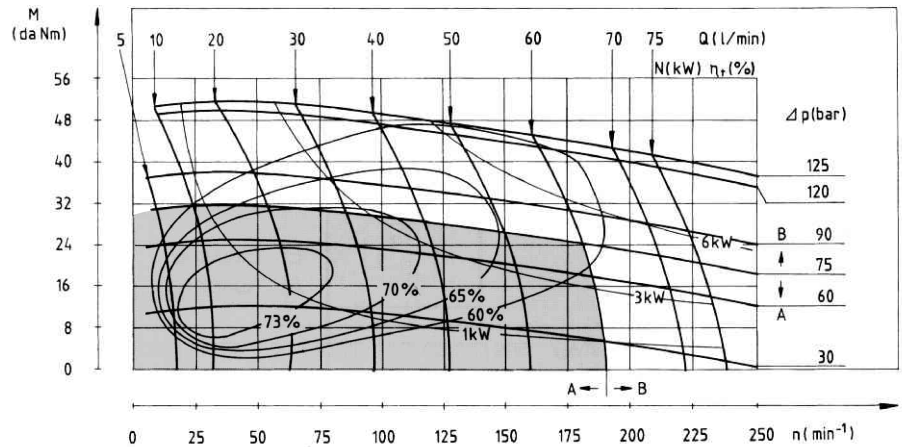

MAP/MAPH400

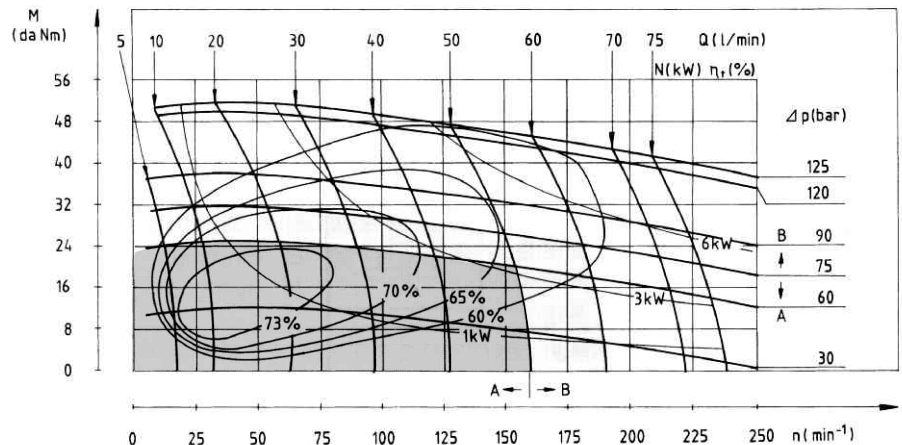

**Dimensions and Mounting Data for MAP**

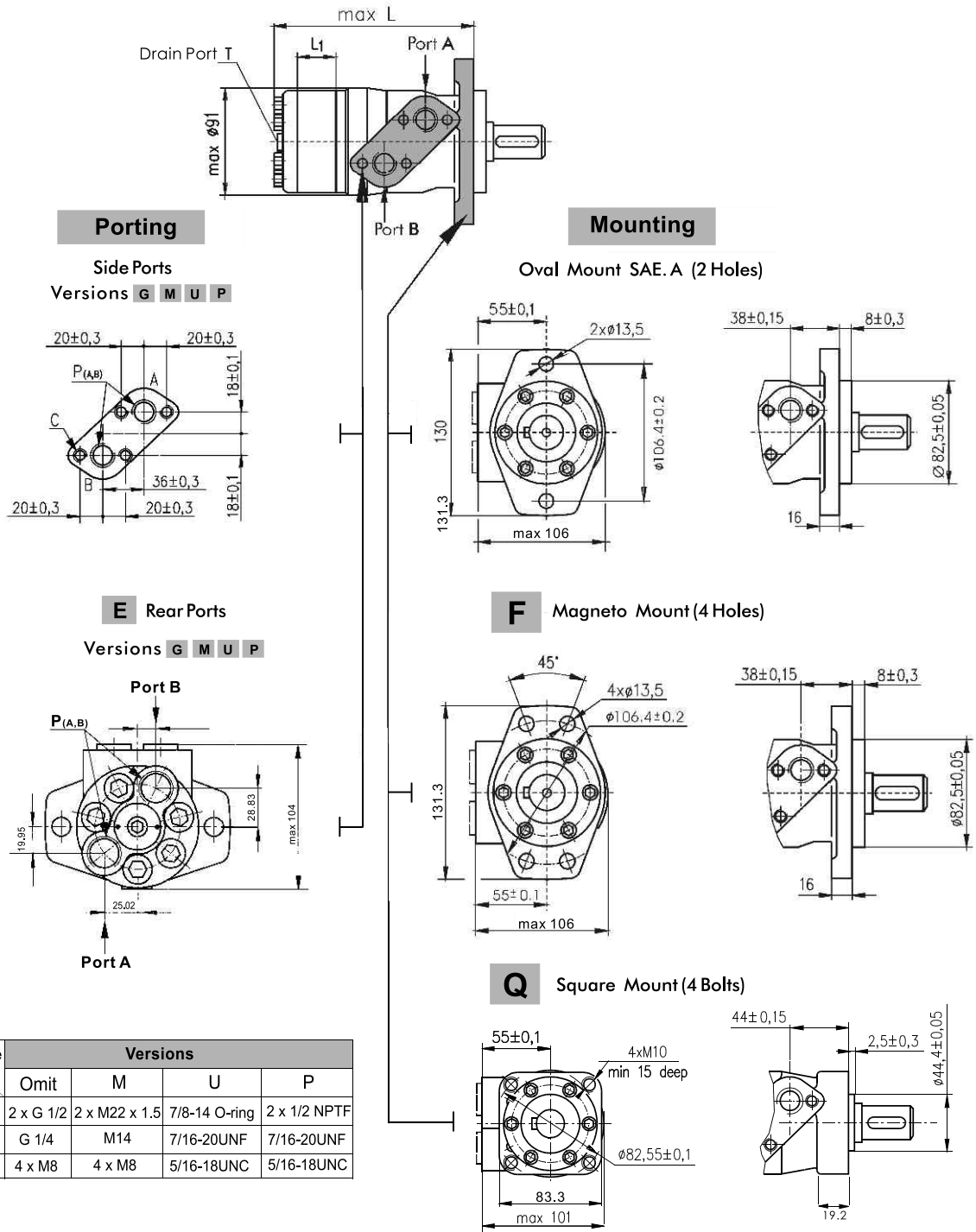

Type	L	Type	L	Type	L	Type	L	L1
MAP(F) 50	137	MAPQ 50	143	MAP(F)E 50	148	MAPQE 50	154	7
MAP(F) 80	140.5	MAPQ 80	146.5	MAP(F)E 80	150.5	MAPQE 80	156.5	10.5
MAP(F) 100	143	MAPQ 100	149	MAP(F)E 100	154	MAPQE 100	160	13
MAP(F) 125	146	MAPQ 125	152	MAP(F)E 125	157	MAPQE 125	163	16
MAP(F) 160	151	MAPQ 160	157	MAP(F)E 160	162	MAPQE 160	168	21
MAP(F) 200	157	MAPQ 200	163	MAP(F)E 200	168	MAPQE 200	174	26
MAP(F) 250	162	MAPQ 250	168	MAP(F)E 250	173	MAPQE 250	179	32
MAP(F) 315	172	MAPQ 315	178	MAP(F)E 315	183	MAPQE 315	189	42
MAP(F) 400	182	MAPQ 400	188	MAP(F)E 400	193	MAPQE 400	199	52

**Dimensions and Mounting Data for MAPW**

**W Wheel Mounting**

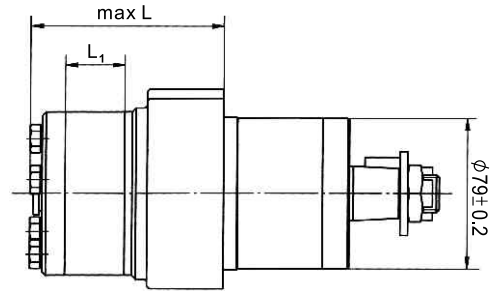
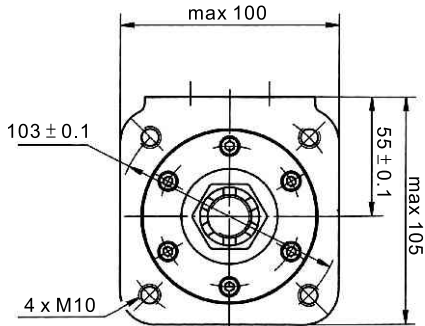

Type	L	L1
MAPW(N) 50	81	7
MAPW(N) 80	84.5	10.5
MAPW(N) 100	87	13
MAPW(N) 125	90	16
MAPW(N) 160	95	21
MAPW(N) 200	100	26
MAPW(N) 250	106	32
MAPW(N) 315	116	42
MAPW(N) 400	126	52

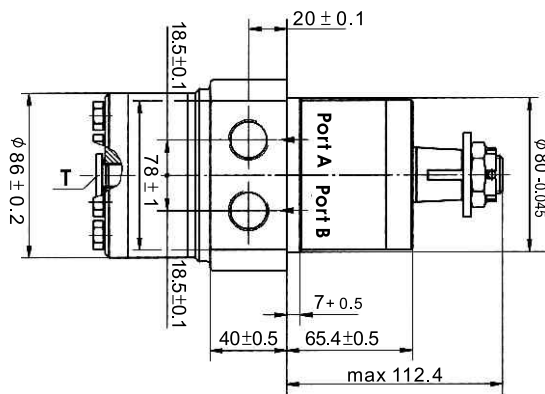

Code	Versions			
	Omit	M	U	P
P(A,B)	2 x G 1/2	2 x M22 x 1.5	7/8-14 O-ring	2 x 1/2 NPTF
T	G 1/4	M14	7/16-20UNF	7/16-20UNF

**Shaft Load**

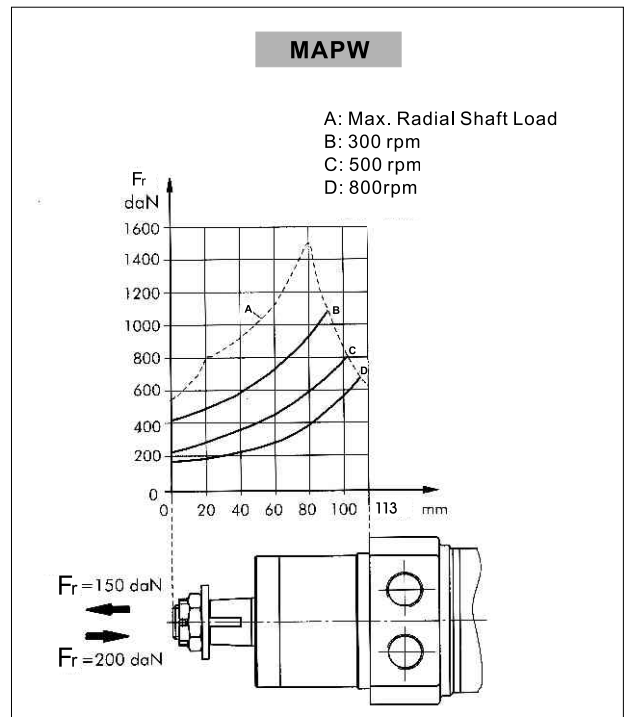
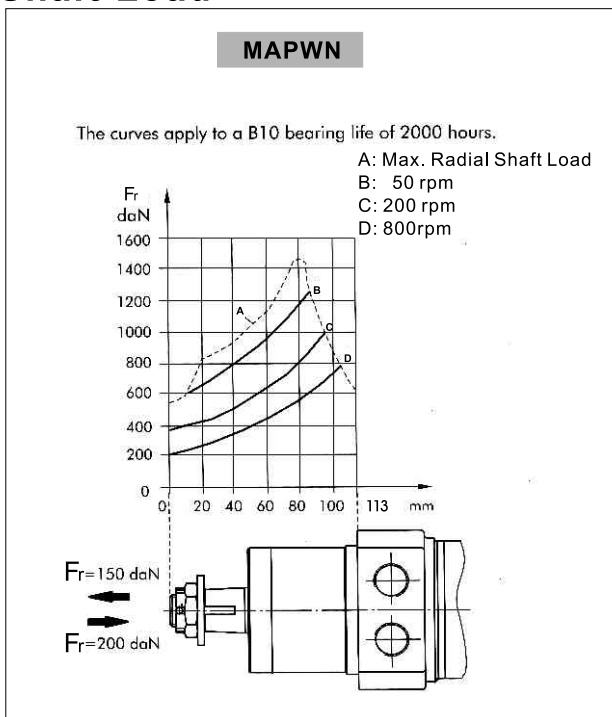

**Shaft Extensions for MAP & MAR Motor**

**C**  $\phi 25$  Straight, Parallel key A8 x 7 x 32  
Max. Torque 34 daNm

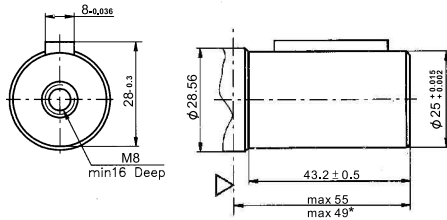

**C2**  $\phi 32$  Straight, Parallel key A10 x 8 x 45  
Max. Torque 77 daNm

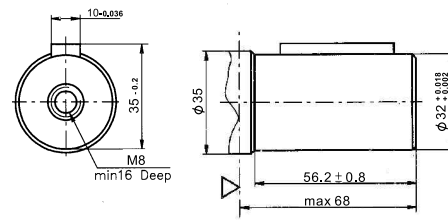

**CO**  $\phi 1"$  Straight, Parallel key 1/4" x 1/4" x 1 1/4"  
Max. Torque 34 daNm

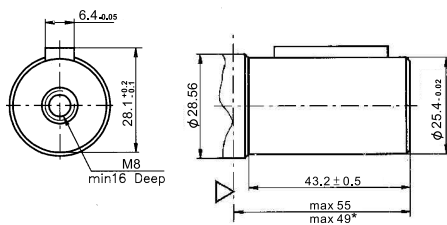

**S** Splined, (SAE 6B)  
Max. Torque 40 daNm

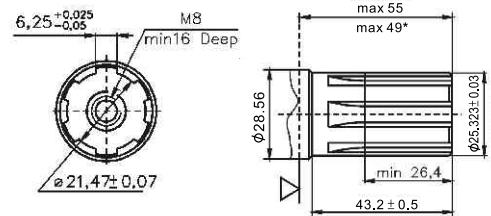

**C1**  $\phi 1 1/4"$  Straight, Parallel key 5/16" x 5/16" x 1 1/4"  
Max. Torque 77 daNm

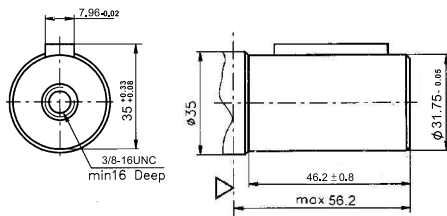

**TA** Tapered 1:8 SAEJ 501, Parallel key 5/16" x 5/16" x 1 1/4"  
Max. Torque 77 daNm

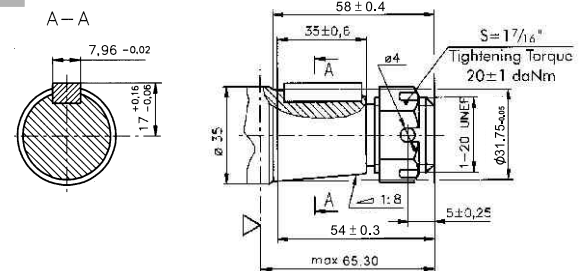

**SH**  $\phi 31.75$  [1 1/4]" Splined 14T, DP 12/24  
Max. Torque 77 daNm

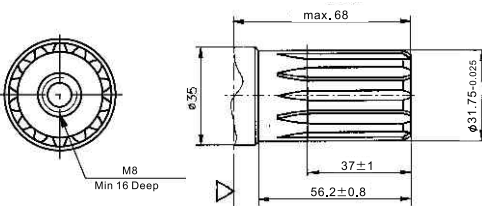

**SB**  $\phi 1 1/4"$  Splined 14T, DP 12/24  
Max. Torque 77 daNm

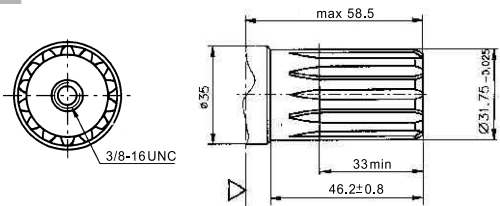

**T** Tapered 1:10, Parallel key B5 x 5 x 14  
Max. Torque 40 daNm

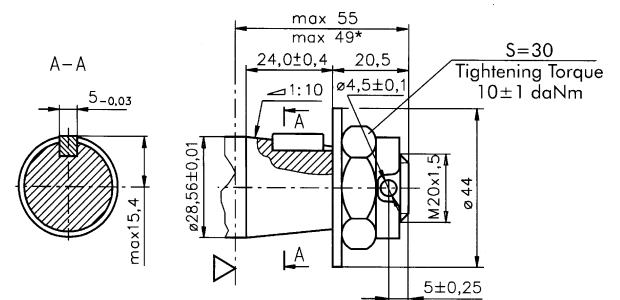

\* Port Q Flange  
▷ Motor Mounting Surface



**Dimensions and Mounting Data for MAPH**

(mm) show in brackets [ ]

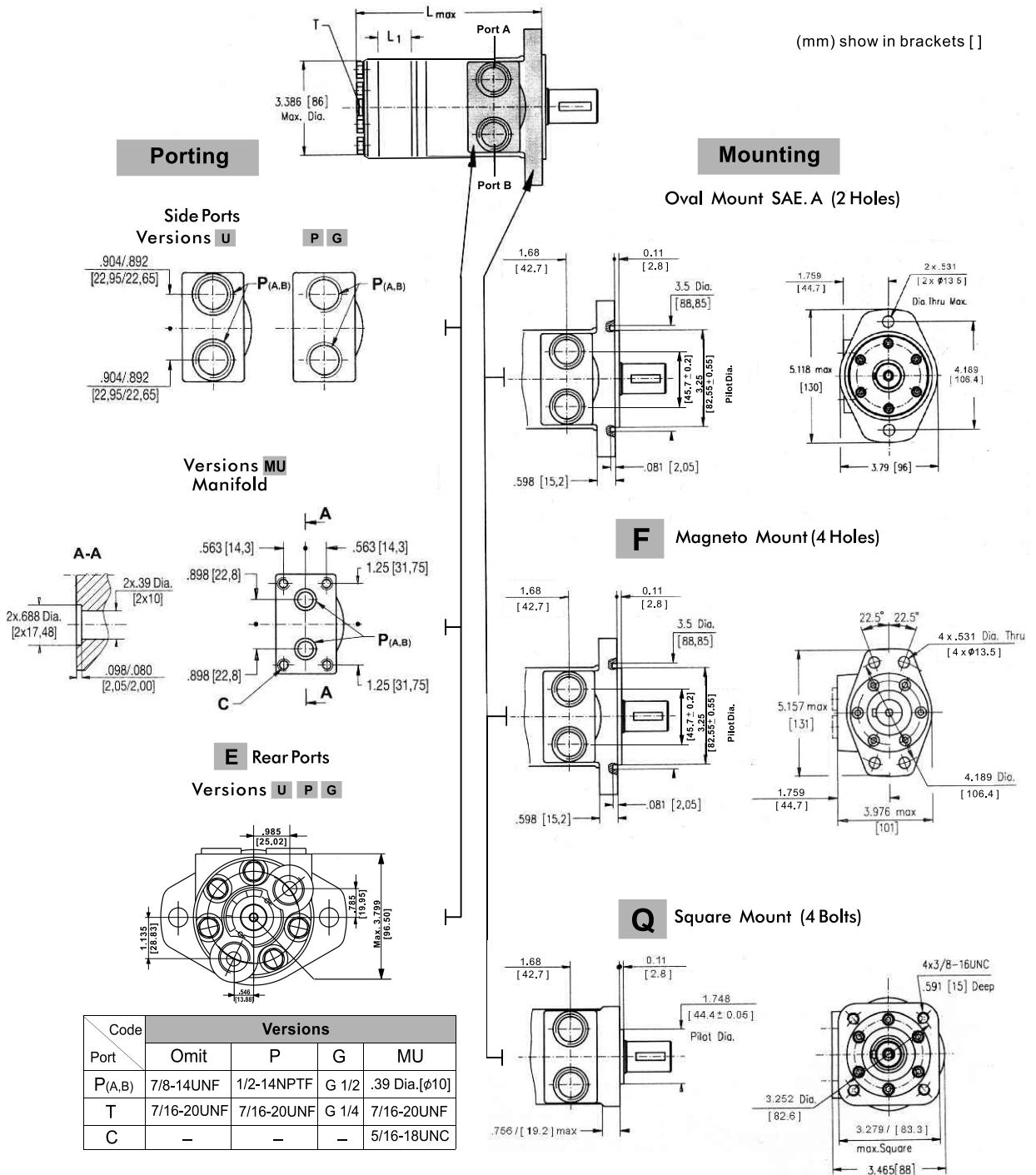

Type	L	Type	L	Type	L	Type	L	L1
MAPH(F)50	141	MAPHQ50	141	MAPH(F)E50	152	MAPHQE50	152	7
MAPH(F)80	144.5	MAPHQ80	144.5	MAPH(F)E80	155.5	MAPHQE80	155.5	10.5
MAPH(F)100	147	MAPHQ100	147	MAPH(F)E100	158	MAPHQE100	158	13
MAPH(F)125	150	MAPHQ125	150	MAPH(F)E125	161	MAPHQE125	161	16
MAPH(F)160	155	MAPHQ160	155	MAPH(F)E160	166	MAPHQE160	166	21
MAPH(F)200	160	MAPHQ200	160	MAPH(F)E200	171	MAPHQE200	171	26
MAPH(F)250	166	MAPHQ250	166	MAPH(F)E250	177	MAPHQE250	177	32
MAPH(F)315	176	MAPHQ315	176	MAPH(F)E315	187	MAPHQE315	187	42
MAPH(F)400	186	MAPHQ400	186	MAPH(F)E400	197	MAPHQE400	197	52

**Shaft Extensions for MAPH & MARS Motor**

(mm) show in brackets [ ]

**C**  $\phi$  25, Parallel key A8 x 7 x 28  
Max. Torque 3900 in-lb [44daNm]

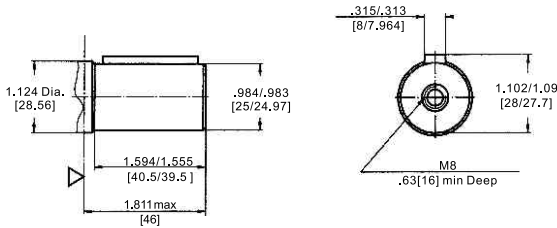

**H** 1" [25.4] Straight w/.406 [10.3] Crosshole  
Max. Torque 3900 in-lb [44daNm]

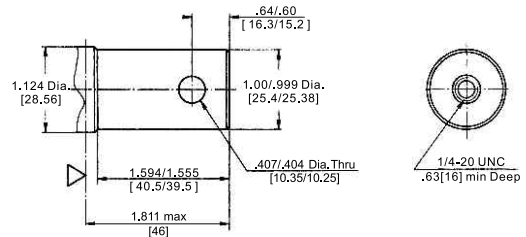

**CO** 1" [25.4] Woodruff key 1/4" x 1"  
Max. Torque 3900 in-lb [44daNm]

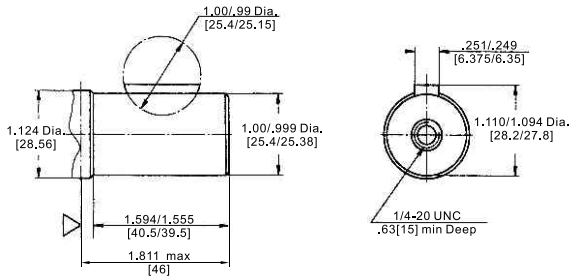

**S** 1" [25.4], SAE 6B Splined  
Max. Torque 3900 in-lb [44daNm]

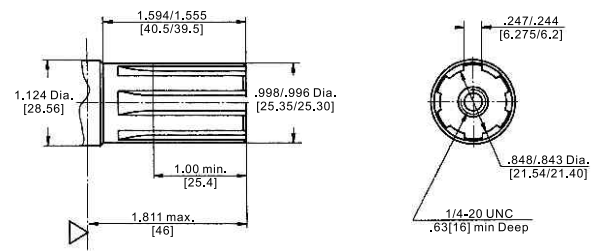

**HA** 1" [25.4] Straight, w/.315 [8] Crosshole  
Max. Torque 3900 in-lb [44daNm]

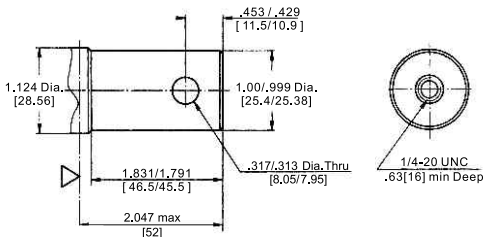

**HB** 1" [25.4] Straight w/.406 [10.3] Crosshole  
Max. Torque 3900 in-lb [44daNm]

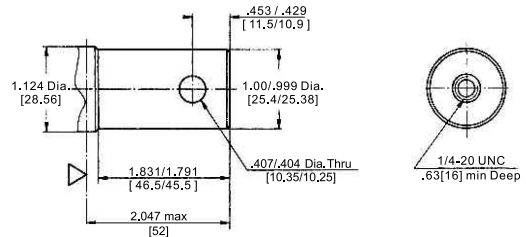

**T** 1" [25.4] SAE J501 Tapered  
Woodruff key 1/4" x 1" SAE J502  
Max. Torque 3900 in-lb [44 daNm]

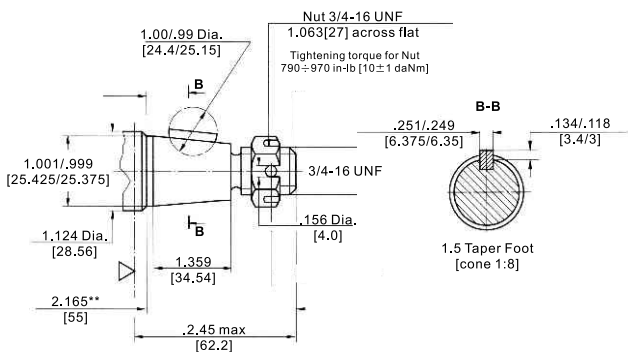

**SA** 13T Splined 7/8" [22.2]  
Max. Torque 3200 in-lb [36daNm]

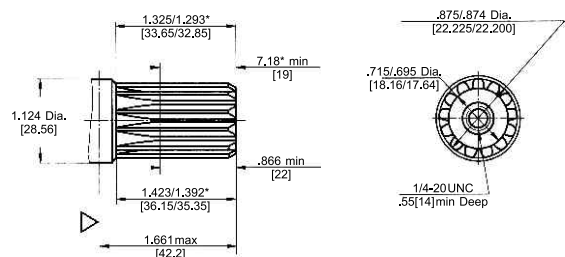

▽ - Motor Mounting Surface  
\* - For SAE, A & F Flange  
\*\* - For Q Flange

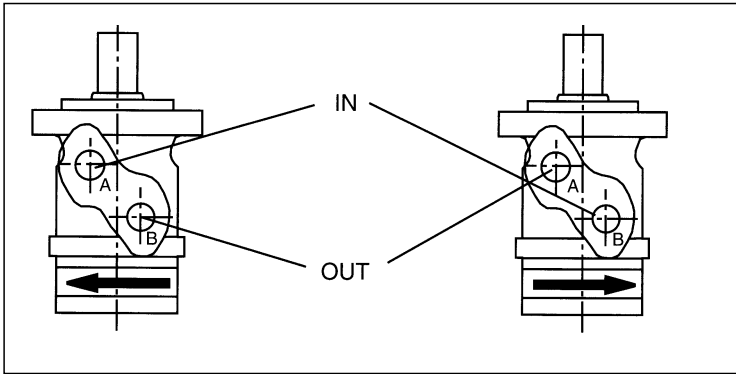

**Rotation Selection**

The MAP & MAPH built-in check valves. The pressure on the shaft seal is identical to the output pressure.

Max. return pressure without drain line or/ Max. pressure in drain line

rpm	Cont. (bar)
0 - 100 rpm	75
100 - 300 rpm	50
300 - 1000 rpm	25

Max. return pressure with drain line

Continuous	160 bar
Intermittent	175 bar
Peak	210 bar

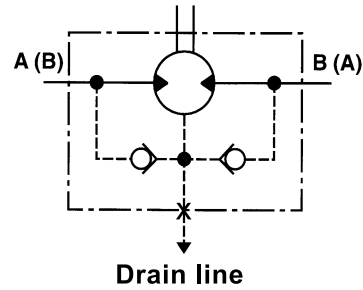

**Shaft Load**

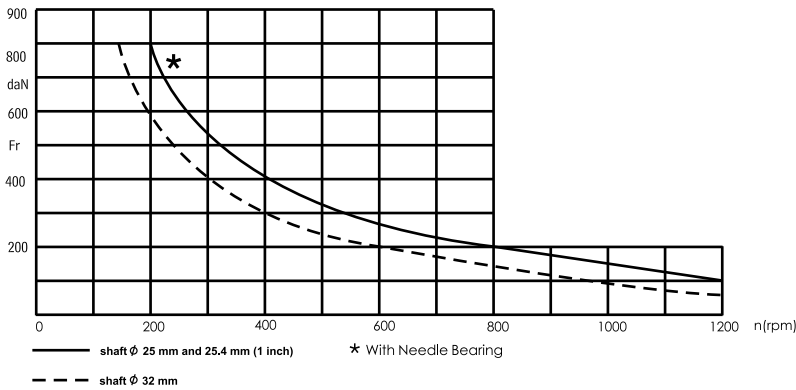

$$F_r = \frac{800}{n} \cdot \frac{25000}{95 + L} \text{ daN}$$

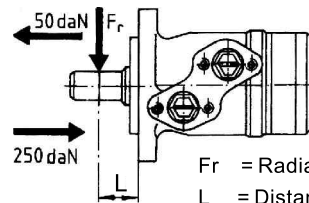

$F_r$  = Radial Force (daN)  
 $L$  = Distance (mm)  
 $n$  = Speed (rpm)

	1	2	3	4	5	6	7	8	9
<b>MAP</b>									

**Pos.1 Mounting Flange**

Omit - Oval Mount, SAE. A 2 holes

- F** - Magneto Mount, 4 holes
- Q** - Square Mount, 4 bolts
- W** - Wheel Mount

**Pos.2 Option Bearings**

Omit - None

- N** - With needle bearings

**Pos.3 Port Type**

Omit - Side Ports

- E** - Rear Ports

**Pos.4 Displacement Code**

- 50** - 50.8cc / 3.1 [in.3/r]
- 80** - 78.8cc / 4.8 [in.3/r]
- 100** - 98.6cc / 6.0 [in.3/r]
- 125** - 123.5cc / 7.5 [in.3/r]
- 160** - 158.6cc / 9.7 [in.3/r]
- 200** - 197.9cc / 12.1 [in.3/r]
- 250** - 247.5cc / 15.1 [in.3/r]
- 315** - 316.5cc / 19.3 [in.3/r]
- 400** - 396.5cc / 24.2 [in.3/r]

**Pos.5 Shaft Extensions (See Page 16)**

- C** -  $\phi$ 25 Straight, Parallel key A8 x 7 x 32

- CO** -  $\phi$ 1" Straight, Parallel key 1/4" x 1/4" x 1 1/4"
- S** -  $\phi$ 25,32 Splined (SAE 6B)
- T** - Tapered 1:10, Parallel key B5 x 5 x 14
- C1** -  $\phi$ 1 1/4" Straight, Parallel key 5/16" x 5/16" x 1 1/4"
- C2** -  $\phi$ 32 Straight, Parallel key A10 x 8 x 45
- TA** - Tapered 1:8 SAE. J501, Parallel key 5/16" x 5/16" x 1 1/4"
- SB** -  $\phi$ 31.75" [1 1/4"] Splined 14T, DP 12/24
- SH** -  $\phi$ 31.75" [1 1/4"] Splined 14T, DP 12/24

**Pos.6 Shaft Seal Version**

Omit - Standard Seal

- D** - High Pressure Seal

**Pos.7 Porting**

Omit - G 1/2

- M** - Metric
- U** - 7/8-14 UNF, O-ring
- P** - 1/2-14 NPTF

**Pos.8 Painting**

Omit - Grey

- B** - Black
- 00** - No Paint

**Pos.9 Rotation**

Omit - Standard Rotation

- R** - Reverse Rotation

	1	2	3	4	5	6	7	8	9
<b>MAPH</b>									

**Pos.1 Mounting Flange**

Omit - Oval Mount, SAE. A 2 holes

- F** - Magneto Mount, 4 holes
- Q** - Square Mount, 4 bolts

**Pos.2 Option Bearings**

Omit - None

- N** - With needle bearings

**Pos.3 Port Type**

Omit - Side Ports

- E** - Rear Ports

**Pos.4 Displacement Code**

- 50** - 50.8cc / 3.1 [in.3/r]
- 80** - 78.8cc / 4.8 [in.3/r]
- 100** - 98.6cc / 6.0 [in.3/r]
- 125** - 123.5cc / 7.5 [in.3/r]
- 160** - 158.6cc / 9.7 [in.3/r]
- 200** - 197.9cc / 12.1 [in.3/r]
- 250** - 247.5cc / 15.1 [in.3/r]
- 315** - 316.5cc / 19.3 [in.3/r]
- 400** - 396.5cc / 24.2 [in.3/r]

**Pos.5 Shaft Extensions (See Page 18)**

- C** -  $\phi$ 25 Straight, Parallel key A8 x 7 x 28

- CO** -  $\phi$ 1" Woodruff key  $\phi$ 1/4" x 1"
- S** -  $\phi$ 25,32 Splined (SAE 6B)
- T** - 1" [25.4] SAE J501 Tapered Woodruff key 1/4" x 1"
- SA** - 13T Splined 7/8" [22.2]
- H** -  $\phi$ 1" (25.4), Straight w/.406[10.3] Crosshole
- HA** -  $\phi$ 1" (25.4), Straight w/.315[8] Crosshole
- HB** -  $\phi$ 1" (25.4), Straight w/.406[10.3] Crosshole

**Pos.6 Shaft Seal Version**

Omit - Standard Seal

- D** - High Pressure Seal

**Pos.7 Porting**

- Omit - 7/8-14 UNF O-ring      **T** : 7/16-20UNF
- P** - 1/2-14 NPTF              **T** : 7/16-20UNF
- G** - G 1/2                         **T** : G 1/4
- MU** - Manifold

**Pos.8 Painting**

Omit - Grey

- B** - Black
- 00** - No Paint

**Pos.9 Rotation**

Omit - Standard Rotation

- R** - Reverse Rotation